

# HC1100

NEAR-BOILING + COLD FILTERED WATER TAP

The InSinkEerator HC1100 Instant Hot Water Tap dispenses near boiling filtered hot water from an easily installed under-sink hot water tank, as well as filtered drinking water. The unit produces the perfect temperature for making hot drinks, speeding up the preparation of pasta or vegetables, cleaning dishes and a host of other kitchen tasks.

## FEATURES & SPECIFICATIONS

- Near boiling filtered hot water instantly.
- Up to 100 cups of steaming hot water per hour.
- Safe, filtered hot or cold drinking water.
- Elegant swiveling spout.
- Tap insulated from heat.
- Tap available in Chrome, Brushed Steel and Matte Black.
- Gentle touch, two lever dispenser, with safety mechanism.
- Tap mounted on either the kitchen work surface or sink. (35mm-38mm drilled hole required in the bench-top)
- Reduces chlorine, lead, and other unpleasant tastes, chemicals and odours from the water.
- Easy to install 2.5 litre stainless steel tank fitted under sink.
- Plugs directly into 240v electrical socket close to appliance.
- Adjustable temperature display on tank.
- Shut-off valve in filter head automatically stops water flow.
- Required supply pressure: 172–862 kPa (1.7–8.6 bar) (25–125 psi)
- Easy to replace filter.
- In-Home Parts and Service Warranty
  - Tank - 2 Year Warranty
  - Filtration System - 1Year Warranty (excluding replacement filter cartridge)



### TAP FINISHES

CHROME

BRUSHED STEEL

MATTE BLACK

### TECHNICAL DIAGRAM & DIMENSIONS

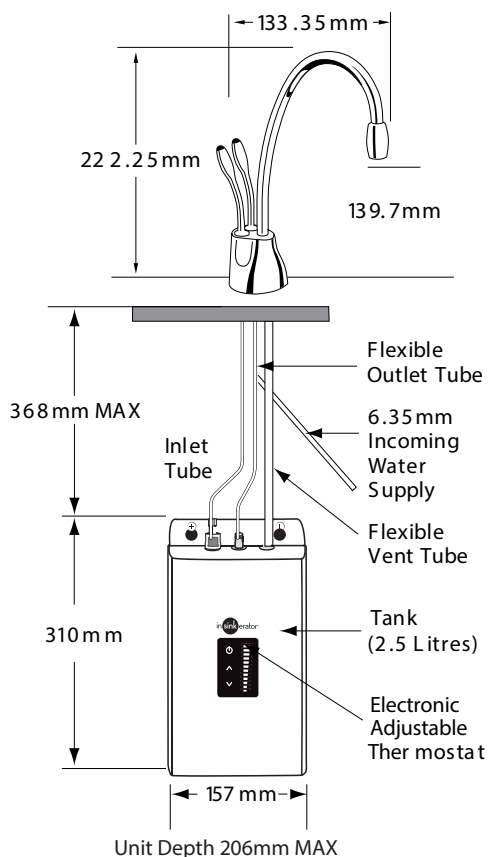

EASY TO INSTALL  
UNDER SINK TANK  
& WATER FILTER

in sink erator<sup>®</sup>  
**hottap**<sup>™</sup>