

GN1100

NEAR-BOILING FILTERED WATER TAP

The InSinkEerator GN1100 Instant Hot Water Tap dispenses near boiling filtered hot water from an easily installed under-sink hot water tank.

The unit produces the perfect temperature for making hot drinks, speeding up the preparation of pasta or vegetables, cleaning dishes and a host of other kitchen tasks.

FEATURES & SPECIFICATIONS

- Near boiling filtered hot water instantly.
- Up to 100 cups of steaming hot water per hour.
- Safe, filtered hot water.
- Elegant swiveling spout.
- Tap insulated from heat.
- Tap available in Chrome, Brushed Steel and Matte Black.
- Gentle touch, lever dispenser, with safety mechanism.
- Tap mounted on either the kitchen work surface or sink. (35mm-38mm drilled hole required in the bench-top)
- Reduces chlorine, lead, and other unpleasant tastes, chemicals and odours from the water.
- Easy to install 2.5 litre stainless steel tank fitted under sink.
- Plugs directly into 240v electrical socket close to appliance.
- Adjustable temperature display on tank.
- Shut-off valve in filter head automatically stops water flow.
- Required supply pressure: 172–862 kPa (1.7–8.6 bar) (25–125 psi)
- Easy to replace filter.
- In-Home Parts and Service Warranty
 - Tank - 2 Year Warranty
 - Filtration System - 1 Year Warranty (excluding replacement filter cartridge)



TAP FINISHES

CHROME

BRUSHED STEEL

MATTE BLACK

TECHNICAL DIAGRAM & DIMENSIONS

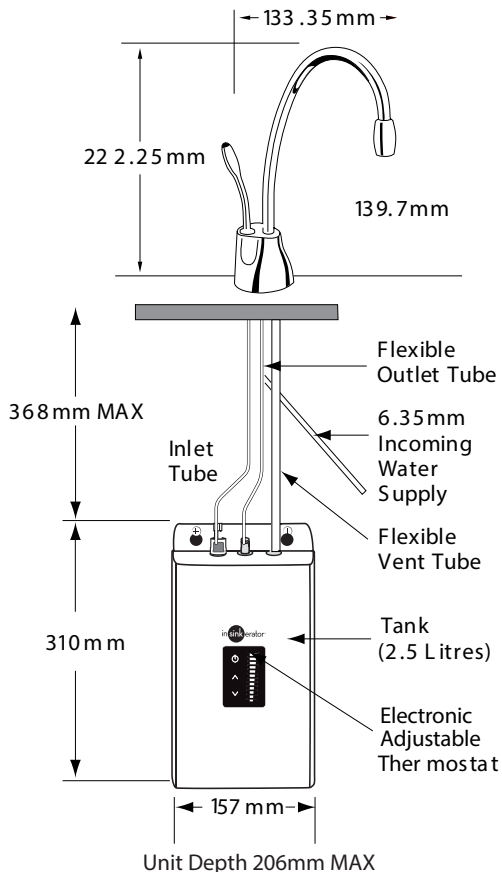

EASY TO INSTALL
UNDER SINK TANK
& WATER FILTER

in sink erator[®]
hottap[™]